



AMERICAN PERC-RITE®

RESIDENTIAL DRIP SYSTEM DESIGN:

The Perc-Rite® Design system features support and certification from **AMERICAN** for the most **COMPETITIVE** and **EFFICIENT** Virginia compliant Drip System for reporting and long-term serviceability.

DESIGN GUIDE:

- USED IN VIRGINIA FOR "LPD" EQUAL AREAS
- FOR USE WITH MOST TREATMENT SYSTEMS
- IDEAL FOR SHALLOW INSTALLATIONS
- The "GREENEST"
- EASIEST O&M
- EASIEST REPORTING
- STANDARD DESIGNS
- COMPETITIVE PACKAGED SYSTEMS



VIRGINIA PERC-RITE®

DESIGN SUBMITTAL

Perc-Rite® CalcTool version 1.4

American Manufacturing Company, Inc.

1-800-345-3132 www.americanonsite.com

JOB NAME:

DATE:

OWNER:

DESIGNER:

VIRGINIA WORKSHEET - Dispersal system design worksheet for

line #	INPUTS	Select One	You must be able to answer YES to both questions in order to continue.
		no	
		no	Are supply and return pipes 1"?
		no	Is the lift to the HU <8' and the run to the HU <30' with 1-1/2" pipe?
1	Adv. Secondary	Select One: Septic or Adv. Secondary?	Secondary may use either ASD 15 or QM Zone Details. Septic effluent may only use ASD 15 Zone Details.
2	45	Perc Rate	Found in column 1 on the Loading Rate Chart. (given by site evaluator)
3	3	Select One # Bedrooms	Design quantity of wastewater to disperse.
4	80	Contour Run Length	Enter the tubing length along contour. If run length is not on table, use the actual run length. Example: 85 ft.
5	100	Supply LF	Length of supply line between hydraulic unit and farthest zone.
6	2	Lift Ft.	Vertical lift from off level in the pump chamber and highest zone elevation.

PERC-RITE® DRIP DESIGN

The **Perc-Rite® Drip System** is a unique fluid handling system for dispersal of effluent wastewater in soil systems. The system incorporates filtration, time and level controlled application and ultra low rate drip distribution. In conditions where aerobic dispersal, such as "Low Pressure Distribution", of septic effluent is required or where land application with the use of conventional soil absorption fields are not acceptable, this system offers the "**GREENEST**" method for subsurface distribution of the wastewater effluent.

The **Perc-Rite® Drip Design System** will accommodate virtually any type of pretreatment process, whether septic tank (anaerobic), aerobic, lagoon, or any type of treatment facility. The "Calc-Tool" is an easy to use .XLS spread sheet that guides the designer through a **Perc-Rite® Design** and is located on our web page;

<http://www.americanonsite.com/american/dg-promo1.html>

To Order Call: (800) 345-3132

www.americanonsite.com

AMERICAN MANUFACTURING COMPANY, INC.

P.O. BOX 97 Elkwood, Va. 22718

1-800-345-3132

ZONE DETAIL NUMBERING SYSTEM

Each zone is designated by a "Z" indicating it is a Zone Detail Designation followed by three groups of numbers, the first is the number of zones, the second is the number of laterals per zone, the third is the runs per lateral.

Z = Zone

Zones

Laterals

Runs/Lat

EXAMPLE 1

Z = Zone

Zones

Laterals

Runs/Lat

This example shows a three zone detail with three lateral per zone and three runs per lateral.

ASD 15 PERC-RITE [®] ZONE DETAIL TABLE - AEROBIC OR ANAEROBIC									
15 GPM AUTOMATIC DRIP SYSTEMS: 24" EMITTER SPACING									
RUN LGTH	50	75	100	125	150	200	225	250	300
#RUN	ZD LF	ZD LF	ZD LF	ZD LF	ZD LF	ZD LF	ZD LF	ZD LF	ZD LF
2						Z121 400	Z121 450	Z121 500	Z121 600
3					Z131 450	Z131 600	Z131 675	Z131 750	Z131 900
4			Z122 400 Z141 400	Z122 500 Z141 500	Z122 600 Z141 600	Z141 800 Z221 800	Z141 900 Z221 900	Z141 1000 Z221 1000	Z141 1200 Z221 1200
5			Z151 500	Z151 625	Z151 750	Z151 1000	Z151 1125		
6		Z123 450 Z132 450	Z123 600 Z132 600	Z132 750	Z132 900	Z231 1200 Z231 900	Z231 1350	Z231 1500	Z231 1800 Z321 1800

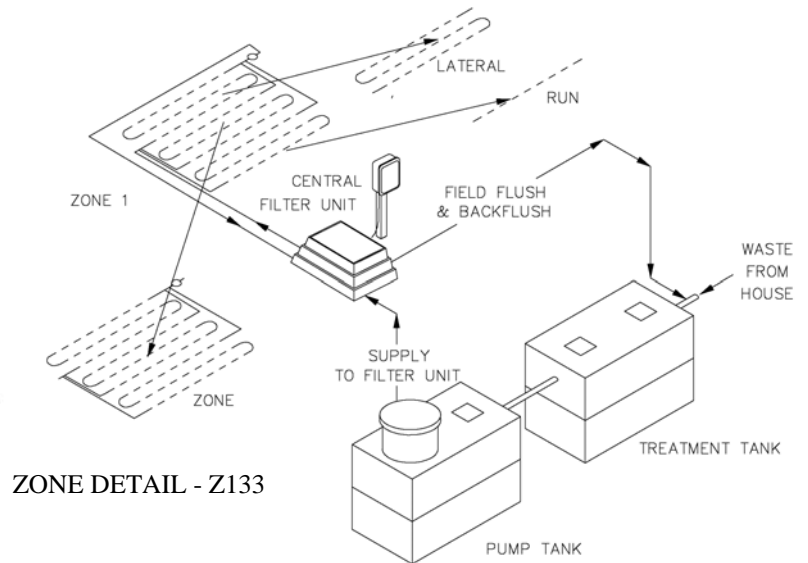
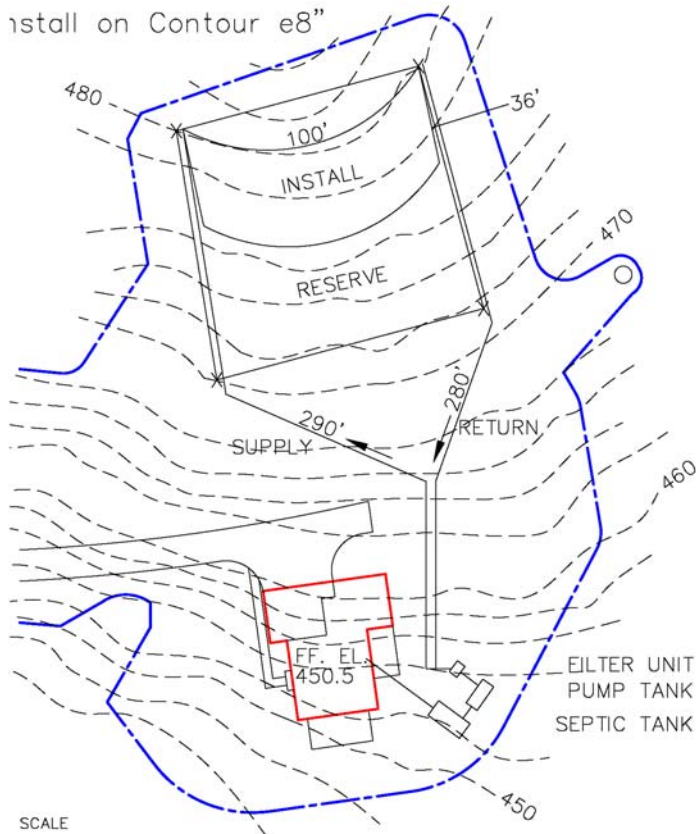

ZONE DETAIL - Z133

ASD15, 15 GPM LIFT & DISTANCE TABLE

Longest supply Manifold Length (feet)	LATERALS					
	2	3	4	5	6	7
1	300'	300'	300'	240'	165'	100'
2						
3	100	98	88	75	74	79
4	150	96	84	69	66	70

The American Calc Tool aids the designer in selecting the appropriate zone detail for typical sites. Once the area and contour length is determined the designer connects components with 1" pipe and with the lift and distance information, determines suitability.

PERC-RITE® DESIGN PROCEDURES - for ENGINEERS & AOSE's

1. **DEMAND ANALYSIS** — The determination of the gallons per day a system needs to disperse is called the demand analysis. The Virginia Regulation determines the amount of wastewater to design for the peak (design) flow. The **Perc-Rite® Drip System** will disperse the average flow each day unless the "Peak " float is enabled at which time the system will disperse effluent at the design daily flow rate.
2. **SITE AND SOILS EVALUATION** — This evaluation is required on each site and the procedures used are not included in this the American manual. However the results of this evaluation are used. The designer must be given the area loading rate and the installation depth. SEE LPD LOADING RATE TABLE.
3. **DELINEATE AREA** — On a site plan or a site sketch, the designer must layout the area of installation on contour. The width along contour must be determined and the distance down slope must be determined in which the tubing can be installed.
4. **SELECT ZONE DETAIL** — Once the area is determined, a standard zone detail is selected based on the width across contour and the number of runs that are needed and can be installed. Select the zone detail for the site from the table.
5. **LAYOUT DISPERSAL SITE** — On a site plan or site sketch show the route for the supply and return pipes. Determine the distance the supply and return pipes travel.
6. **LAYOUT DETAILS IN PUMP TANK AREA** — On a site plan or site sketch show the layout of the tanks, filter unit and the control panel.
7. **FILL OUT WORKSHEET** — The worksheet confirms the information necessary to show the drip system will work for the proposed site. The site sketch, hydraulic profile, standard details, and the worksheet is enough information to describe the system for the site.

STANDARD SITE AND SOIL EVALUATION APPLIES

CONVENTIONAL EVALUATION — Most site evaluations start with investigating if a conventional system is appropriate. When a conventional system is feasible, a Perc-Rite® drip system may not be the preferred option.

ALTERNATIVE EVALUATIONS — When a conventional system is not feasible, we already know the site has limitations so drip should be an option. The Perc-Rite® drip system is the most economical for a Low Pressure Distribution system loading rate area design. A Perc-Rite® drip system area is calculated by multiplying the bottom area off the LPD chart by 3. The Perc-Rite® drip system Calc-Tool will lead the designer through this calculation. Site limitations frequently arise from shallow soils. The minimum installation depth for septic tank effluent in the Regulation is 18". There is no minimum for treated effluent. Soil cover of 6" is sufficient for most lawn activities and provides sufficient protection in most cases.

ENGINEERED SOLUTIONS — Engineers in Virginia have the ability to design systems outside the Regulation using engineering best practices and generally accepted standards. The engineers at American are well versed in state of the art onsite design practices for most situations and are available to assist Virginia Engineers for those most difficult sites.

Virginia GMP 107 STANDARD APPLIES

GMP 107 is the Virginia Standard for drip dispersal application. It requires design for equal distribution of septic or secondary effluent up to 1200 gallons per day with the minimum submission of Type II - informal plans.

Drip dispersal consists of micro-dosing effluent into the soil to maintain unsaturated flow of effluent for final treatment and recycle back into the environment. Equal distribution is imperative and must be applied first, then manage micro-dosing. Flow equalization is necessary for the required Timed Dosing and 18 hours of storage is the Virginia Standard. The GMP requires color coded tubing, filtration and Automatic field flushing at 2 feet per second with flushings returning to the treatment system. Equal Distribution is calculated including "Drain Down" and a Perc-Rite® design with "Top Feed Manifolds" manages this most effectively. Any design that does not fit these criteria must be "**Engineered**" as being outside the regs.

AMERICAN MANUFACTURING COMPANY, INC.

P.O. BOX 97 Elkwood, Va. 22718

1-800-345-3132



PERC-RITE® DRIP - The "GREENEST" ALTERNATIVE

BEST ALTERNATIVE FOR MOST SITE LIMITATIONS

The patented Perc-Rite® processes proves the ability of drip dispersal technology to manage single family, commercial and large flow projects with challenging site conditions. The system features totally automatic control. Perc-Rite® is suitable for application with all treatment offering the lowest risk and best solution for all onsite dispersal needs. Perc-Rite® Drip Dispersal Systems are the most appropriate technology for;

SMALL FOOTPRINTS — Whether utilizing an up to 50% reduction from conventional trench system area with septic tank effluent, further reduced advanced secondary area loading rates, or the minimum "Micro Mound" basal area loading rates, Perc-Rite® drip dispersal systems offer a superior, sustainable onsite system to address those needs.

SHALLOW LIMITATIONS — Perc-Rite®'s shallow placement, 6"-12" from the surface, maximizes the depth to limitations such as rock, restriction and seasonal high water table. There is no minimum installation depth requirement in Virginia.

IRREGULAR SHAPED SITES — Equal distribution is a Perc-Rite® characteristic and with our design standards and pressure compensating emitters, a variety of site configurations can be accommodated. Several suitable areas of varying sizes may be utilized maintaining the same gallons per linear foot loading rate in all areas. Absorption areas **do not have to be exact squares or rectangles**. Soil and landscape suitability may be maximized without the design constraints of conventional trench systems. As a **shallow or ultra shallow** placed gravel-less system with minimum or no excavation or site disturbance, drip dispersal can be sited and installed within **treed sites**.

SLOWLY PERMEABLE SOILS — The Perc Rite® technology's characteristic low volume, time dosed, equal distribution of effluent dispersed over an entire soil adsorption area is particularly applicable to slowly permeable soils. The equipment provides for zone specific controlled dosing to minimize risk of surfacing from the instantaneous dose, which is the most sensitive process in drip dispersal.

SLOPING SITES — Drip Dispersal has a great advantage over other soil based dispersal systems, as the absorption field installation does not require conventional trench type excavation. As a **shallow or ultra shallow** placed system installations on steeply sloping sites of 15 -60% + are easily accommodated. Redistribution of effluent to the lower portions of the system by gravity at pump cut off is eliminated by the utilization of Top Feed™ Manifolds. Installation minimum depths do not increase with slope.

The PERC-RITE® ALTERNATIVE

Drip distribution is the most appropriate dispersal method for treated and nitrified effluent for onsite wastewater application.

Dispersal of Nitrates in the shallow soils is the "Best Practice" for environmental protection.

The adjacent sizing comparison shows drip dispersal can be used in conventionally sized or reduced footprint designs.

